



Centre for Data Science and Artificial Intelligence (DSAIL)

Minds, Machines and Matrices - 2026

Embedded Systems – The Backbone of IoT

By

Jason Kabi

Junior Research Fellow

Topics

- **Introduction to embedded systems.**
 - What is an embedded system
 - Operation of an embedded system
 - Attributes of an embedded system
- **Embedded system Essential:**
 - Data transmission / digital transmission
 - Serial communication
 - Analog sensor data pipeline
 - Digital sensor data pipeline
- **Embedded system as the back bone if IoT**
 - IoT architecture – essential
 - LoRaWAN – Introduction
 - Setting up LoRaWAN Network – What is needed (example from DSAIL)
 - Introduction to RealTime Operating System (RTOS)
- **Practical – Farewell to MbedOS**

Computers, Processors, and Microcontrollers

- **Operating system:** A manager of resources provided by the underlying architecture.
- A **computer:** Combines a central processing unit (CPU), random access memory (RAM), read only memory (ROM), and input/output (I/O) ports.
- A **processor:** Often called the Central Processing Unit (CPU)—is the primary component of a computer that performs most of the data processing and calculations. It acts as the "brain" of the system, responsible for fetching, decoding, and executing instructions.
- A **microcontroller:** Contains all the components of a computer (processor, memory, I/O) on a single chip. Microcontrollers are designed for **embedded applications**

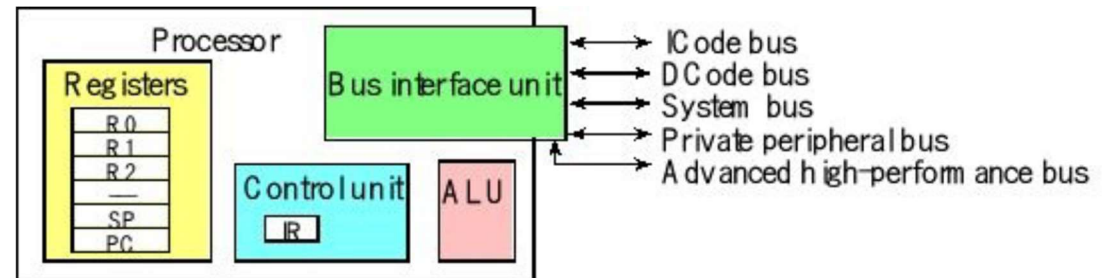
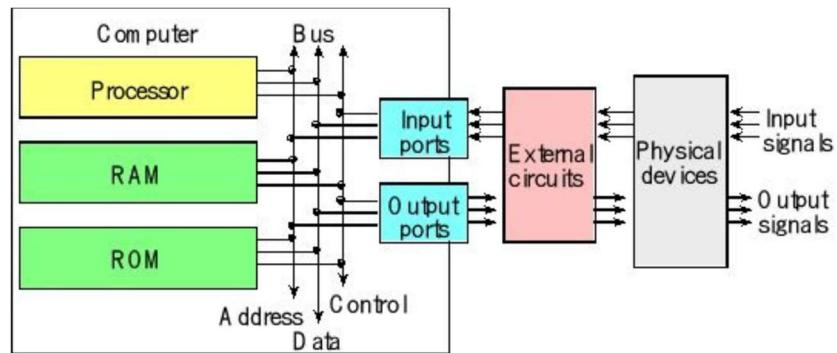

Introduction to Embedded Systems

- **Embed-** incorporate or integrate something in a larger system.
- **Embedded system:** A computational system that is based on the integration of both software and hardware in order to perform specific tasks
- There are two classifications of embedded systems
 1. Transformative: Collects data from inputs, makes decisions and affects its environments by driving actuators.
 2. Reactive: Collects data in a continuous fashion
- Use of specialized ICs called **microcontrollers** that have features to simplify monitoring and control (MCU – CPUs peripheral, support circuits, memory)
- **Example:**
 - A microcontroller inside a washing machine to control cycles, fridge for monitoring temperature
 - At DSAIL we have water level monitoring sensors to monitor water level changes along rivers.

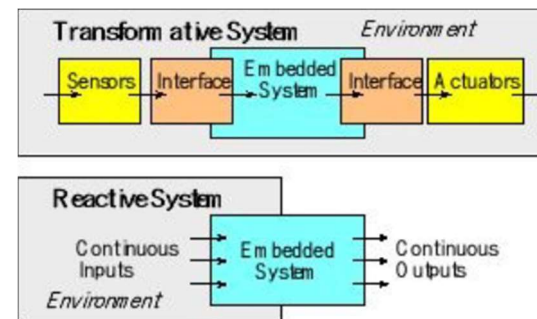

Operations of an Embedded System

- **Closed Loop Control:** controlling an output variable based on one or more input measurements
 - Example: adjusting temperature, changing direction
- **Sequencing:** Controlling on output through a sequence of steps.
- **Signal Conditioning And Processing:** Averaging together sensor readings, signal conditioning, filtering out noise.
- **Communication And Processing :** interaction with other systems and subsystems.



Camera Trap



Water Level sensor



Acoustics Sensor

Attributes of an Embedded System

- **Interfacing with inputs and outputs:** Embedded computers need to sense the environment and the issue control commands in response (analog, digital, ADC, DAC).
- **Specialized peripheral hardware circuits** – often signals must be processed before they are converted to the digital domain for the CPU (Amplification, scaling down signals, filtering noise)
- **Concurrency:** Embedded controllers must manage multiple activities concurrently, often with precise control of the timing
- **Responsiveness:** Provision of enough responsiveness utilize sharing the CPU's time across many activities.
 - Processor must be fast enough to complete the critical processing before its deadline. The developer should optimize code to do the necessary work with very few instructions.
 - Processor need to stay focused on the critical processing
 - Split processing and the communication
- **Reliability and fault handling:** Embedded systems are expected to work correctly and reliably (unlike normal computers the user cannot reboot). Also, minimize the impact of failure.
- **Diagnostics:** Very easy to find and repair faulty component quickly and easily. Hard coded diagnostics support (printers, scanners and fridges)
- **Constraints:** Embedded systems must not be too (large, expensive, heavy)

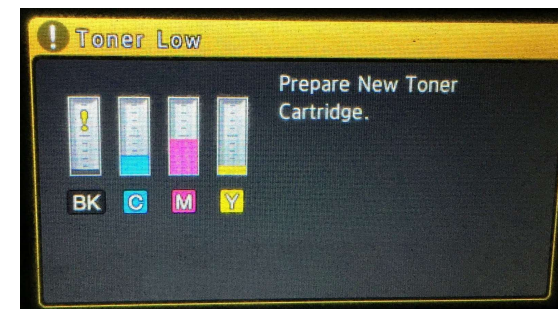

Embedded system Essential: Digital Data Transmission

- **Def:** Transferring data between 2 or more digital devices. Data is usually transferred in form of bits. (Channels: Fiber optic, conductor, wireless)
- Digital data transmission can either be **parallel** or **serial**

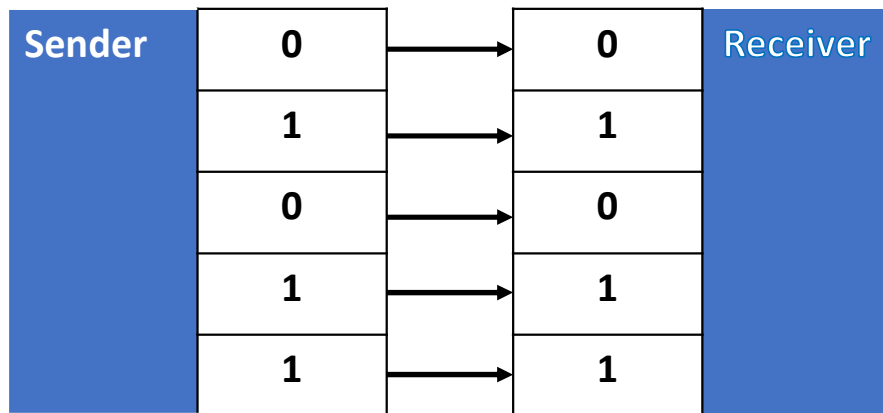

Parallel transmission

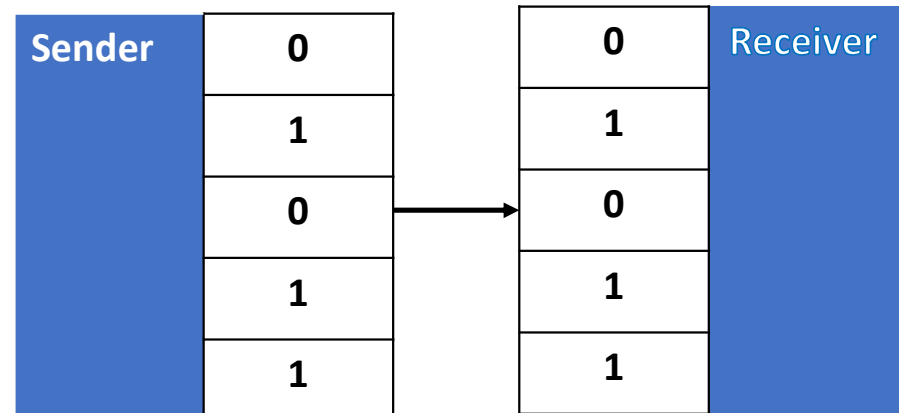

Serial transmission

Cont.

- **Parallel Data Transmission**

- Multiple data bits are sent at the same time over multiple channels
- Data reaches the receiver in one go.
- More channels
- Very expensive

- **Serial data transmission**

- Data bits are sent through a single channel one after the other.
- One communication channel
- Less expensive
- The technology used in serial communication is **Shift Registers**
- A shift register is like a digital conveyor belt with memory cells called **flip-flops**
- A clock signal is needed – controls everything.
- NB: With every clock pulse, the binary value currently inside the register moves one step, bit after bit, until you have the whole digital word.
- You can have a start bit and a stop bit

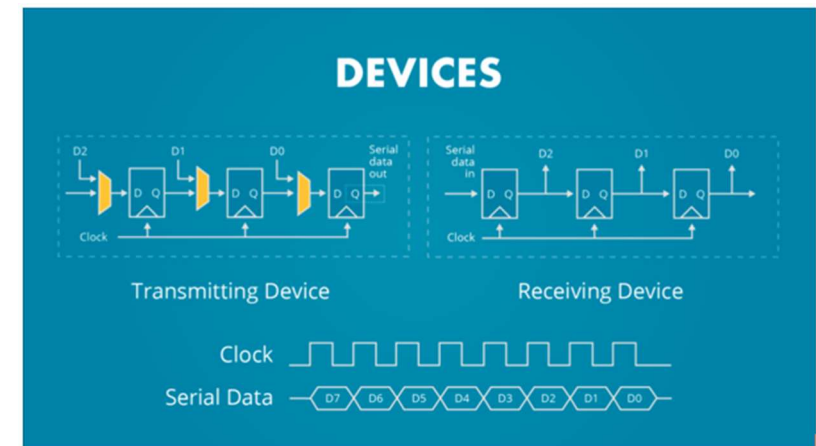

Serial communication

- Under Serial communication, the main categories are - Synchronous and Asynchronous
 - **Synchronous** – Clock signal is needed
 - **Asynchronous** – Clock signal is not needed.
- Under synchronous, the method is.

SPI(Serial Peripheral Interface)

- It involves 2 ICs /shift registers working together, the controller/master and target/slave
- Movement of the bits is bidirectional – half duplex
- The controller is more powerful since it controls the clock and the chip select
- Common pins (MOSI/COTI, MISO/CITO, SCK, CS)
- Demerits: No data acknowledgement once sent, no addressing(cs for every target), no error checking mechanism

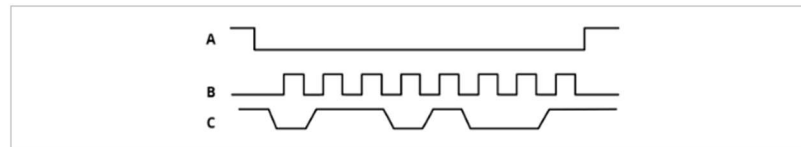

Quiz

Identify the correct answer below:

In an SPI network, three signals are observed on the pins of a certain Target device. It is known that in this mode, the data is clocked in on the rising edge of the clock. Note that the MSB (Most Significant Bit) is transmitted first in any data word in SPI.

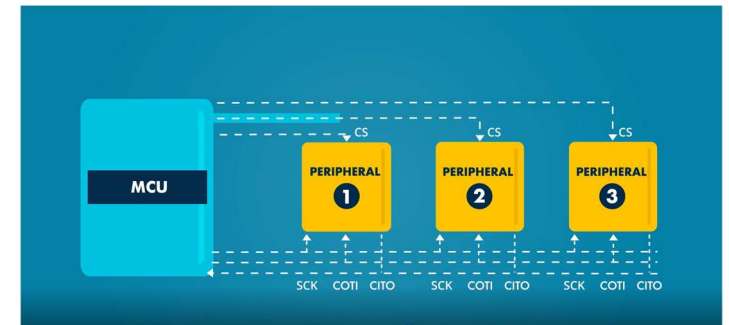

Cont.

I2C – Inter Integrated Circuit

Protocol widely used in serial communication (Introduced by Philips S.C IN 1982)

- Two wire communication (SDA –Serial Data, SCL- Serial Clock)
- Half duplex – Can follow in two direction but not simultaneous
- Addressing – Each target is identified with a unique 7-bit or 10-bit address
- Error handling include NACK/ACK bits to confirm successful data transmission

Steps

- Start – The master initiates communication by pulling the SDA line low while SCL remains high
- Addressing – The master sends the 7-bit address of the target slave followed by a read/write bits
- Acknowledgement – The addressed slave responds by pulling SDA low during the next clock pulse
- Data transfer – Data is sent in 8-bit frames, followed by an ACK/NACK bit after each frame
- Stop conditions – The masters ends communication by realizing SDA to high while SCL is High

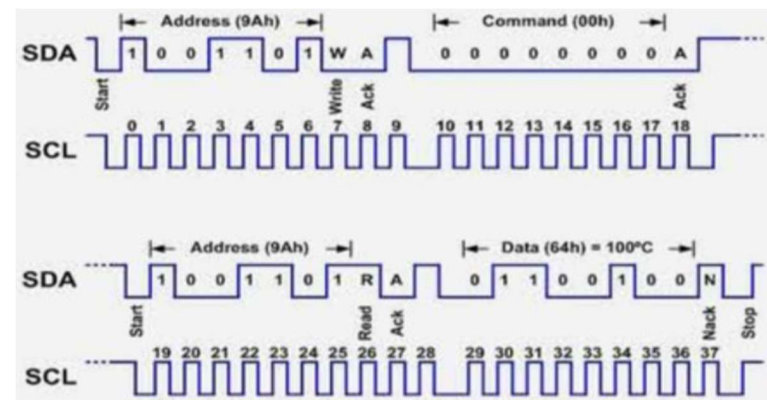

Cont.

- Under Asynchronous, the method is.
- **UART(Universal Asynchronous Receiver/Transmitter)**
 - No clock
 - Data transmission rate known as the baud rate is measured in bits per second
 - The baud rate is prearranged between the transmitter and the receiver
 - Common connections: TX and RX
 - Some UARTs have the ability to be configured as synchronous : USART(Universal synchronous/asynchronous)
 - Framing bits are required at the beginning of the data and the end of the data.
 - Data transmission is usually in 2 patterns
 - 8-bit transmission
 - 8-bit transmission plus parity pattern
 - Parity pattern – Error checking mechanism that helps to ensure data is correctly received.

(LO3) The data pattern of a certain asynchronous communication link is represented below. It starts in an idle state.

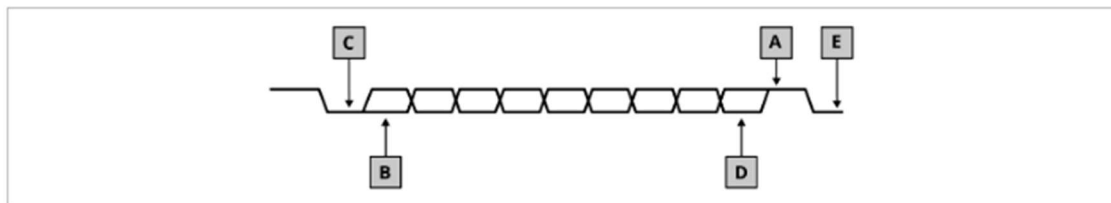

Quiz

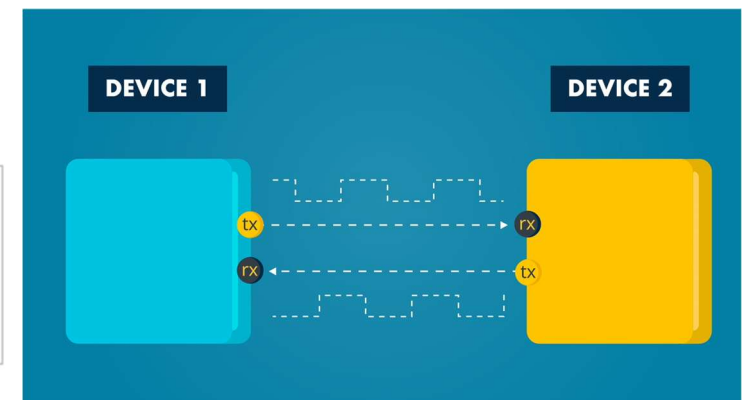

Analog communication(AnalogIn)

- With the ADC the continuous analog wave is sampled and converted to a digital number (Analog Sensor – Wave – ADC – Parallel binary bits – shift register – serial bits) – Below is a Master pipeline for an analog sensor

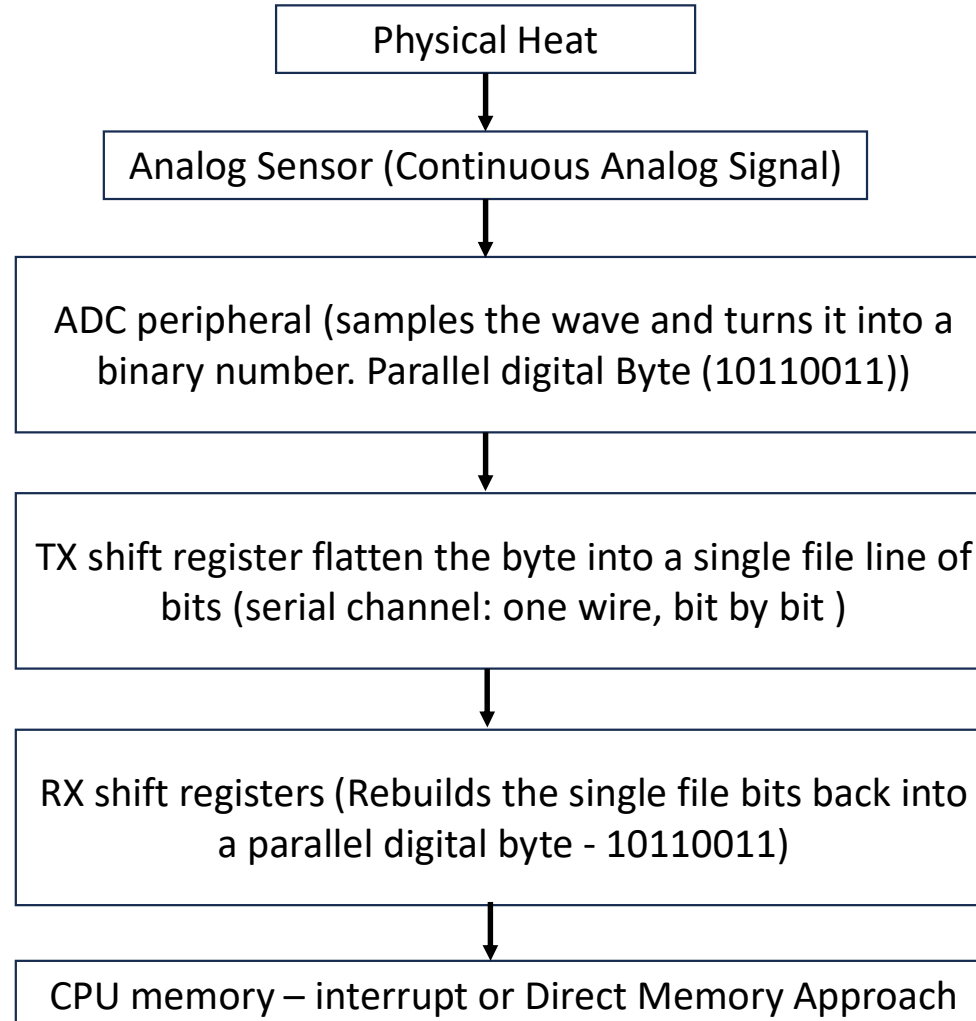

Embedded system – Internet of Things connection

- Embedded systems are the backbone of IoT
- An IoT device is an embedded system connected to the internet.

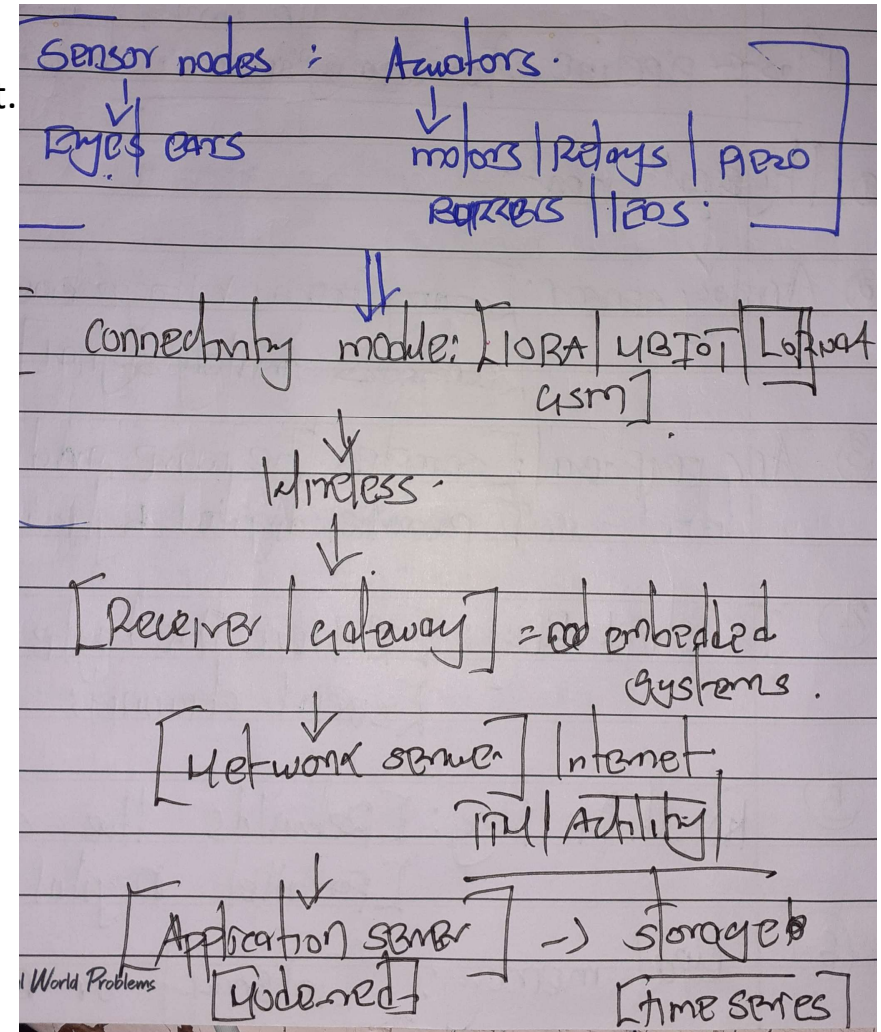
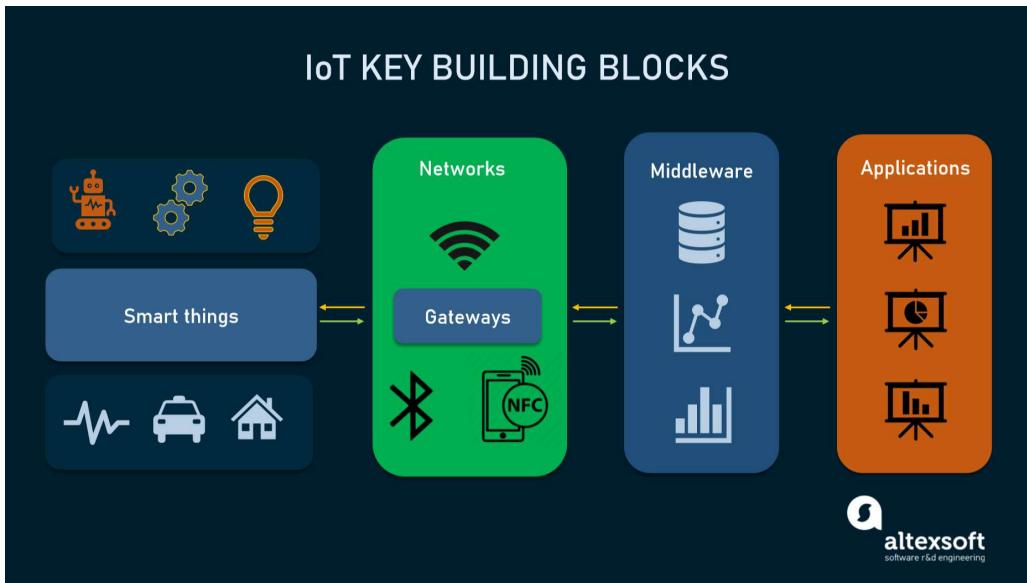

Connectivity- Wireless Sensor Network

- Low power wireless protocols are designed to transmit data using very little energy, allowing IoT devices to last for long using constrained power sources (batteries) – The two strengths of these protocols is **Low power and Self configuration**.
- **Categories**
 - Short range protocols – BLE - Bluetooth low energy
 - Medium Range protocols – Zigbee
 - Long Range protocols – (unlicensed: **LoRaWAN**, Sigfox), (licensed: NB-IoT, LTE)

Let's Focus on LoRaWAN

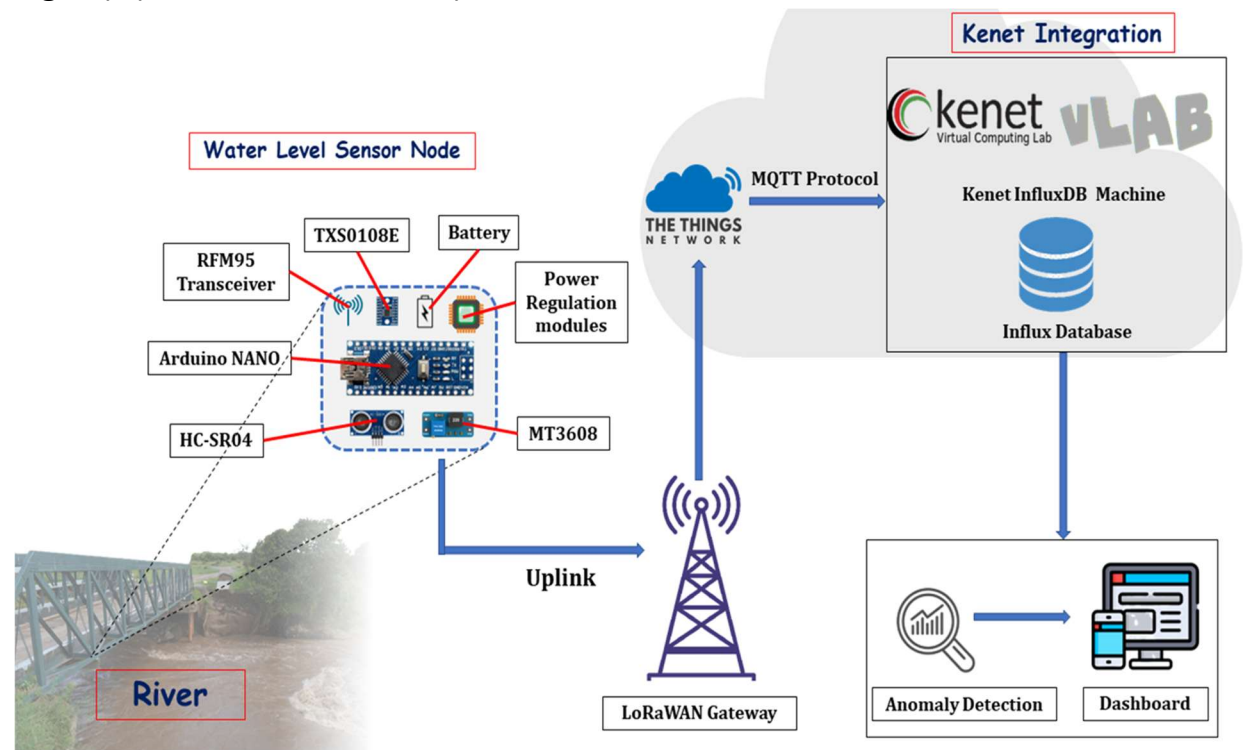

LoRaWAN

- **Definitions**
- **LoRa** – Physical radio communication technique based on the CSS technology. (Developed by Semtech – producer of analog and mixed signal semiconductors)
 - What is LoRa used for – sending small amount of data over long distances (Record - 960 miles) – Suited for IoT.
- **LoRaWAN** – Media Access Control (MAC) layer protocol built on top of LoRa modulation. It is the software layer that defines how to use the LoRa hardware.
- LoRaWAN is developed and maintained by the LoRa Alliance – Fremont, California
- LoRa Alliance – Non-profit technology ecosystem of which Semtech is a founding member.



You want to established, what do you need.

- LoRaWAN gateway (Kerlink, The Things Industry, MultiTech)
- Internet access for the gateway (LTE, ethernet, Wi-Fi)
- Power supply for the gateway
- Sensor node
- Network server (Actility, The Things Network)
- Cloud service to store the data and run visualization tools

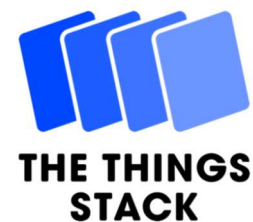

Practical

Farewell to MbedOS



Thank you.